

Invisible Fence[®]

BRAND

ICT 775 Transmitter Operation and Installation Manual



Your dog safe @home.[®]

Made in the USA

Thank you for choosing an Invisible Fence® Pet Containment System

We believe that you now own the highest quality electronic pet containment system made anywhere. We support this claim by backing Invisible Fence Brand products with a One-Year, Money-Back Performance Guarantee*, and Warranties which include lightning and surge damage. Refer to your warranty card or the back of your sales contract for complete details. All of this is backed up by our inter-

national network of local Invisible Fence professionals who offer you professional installation, Safe Dog® pet training, and prompt service.

You are the most important judge of our products and services. When you tell us that we have met or exceeded your expectations for Invisible Fence products, then we are achieving our goal: to continuously keep your pet safe at home.™

* Good only on professionally installed systems.

Important Safeguards

1. Read and Retain Manuals: Read all of the operating and training instructions before installing and/or using your new Invisible Fence Brand pet containment system.

2. Training: Train your pet according to the instructions in Invisible Fence training manuals. Complete all of the steps before allowing your pet to run free.

3. Obey all Cautions and Warnings: Adhere to all of the cautions and warnings contained in this manual and all other manuals pertaining to your Invisible Fence system, and all Invisible Fence system components.

4. Service and Repair: Other than repairing the signal field wire, do not attempt to service any Invisible Fence equipment yourself. Refer all service to an authorized Invisible Fence professional only.

5. For Animal Use Only: All Invisible Fence pet containment systems are designed for animal use only. Never attempt to use this product for any purpose not specifically described in this manual.

IMPORTANT: If, for any reason, your Invisible Fence system does not operate as described in this manual, or if you encounter any difficulty training your pet, call your Invisible Fence professional immediately.



Warning: The following precautions should always be taken.

1. Never attempt to install an Invisible Fence pet containment system unless you have first consulted your Invisible Fence professional and have Invisible Fence installation instructions.

2. Never install an Invisible Fence transmitter, LP3000, or any Invisible Fence system component other than signal field wire outdoors or where they could be exposed to the outdoor elements, doing so will void the manufacturer's warranties.

3. Check the transmitter periodically to make sure that it is operating properly and is producing a signal along the signal field wire.

4. Caution: Always take the Computer Collar® off your pet before making any adjustment to your Invisible Fence system.

5. If you have any questions about any aspect of your Invisible Fence system, please call your Invisible Fence professional immediately.



Warning: Never install, connect or service any Invisible Fence system component or equipment when there is a thunder or lightning storm in the area.



Caution: Before starting any work, unplug the transmitter's 12vAC transformer from the 110v outlet and the transmitter. Turn off the electric service at the circuit breaker panel.



Warning: If you have any reason to believe that your pet may pose a danger to others, or that it may harm itself if it is not kept from crossing the Invisible Boundary® signal wire, you should not rely solely on this product to contain your pet.

Invisible Fence® pet containment will not work unless:

1. The 12vAC transformer is plugged into the transmitter and is plugged into a 110vAC outlet.
2. The transmitter is on, connected to the signal field wire, and producing a signal along the wire.
3. The signal field wire is intact, continuous, and the transmitter's green LED is blinking on and off.
4. The Computer Collar® is correctly fitted and worn by your pet.

The Computer Collar is adjusted so that the receiver posts are touching your pet's skin.

5. The Power Cap® battery in the receiver is good and is correctly installed.
6. You train your pet as prescribed in Invisible Fence training manuals.

Do Not become overly confident that your pet has become conditioned to the Invisible Fence system sooner than expected. Complete all of the training steps before allowing your pet to run free.

If you have any questions about any aspect of your Invisible Fence system, please call your Invisible Fence professional immediately.

About Thunder or Electrical Storms

Even though your Invisible Fence system is equipped with lightning surge protection, it is still possible that it may be damaged during a thunder storm, or when an electrical storm is in the area where you live. For added peace of mind, you may want to take the Computer Collar off your pet before an electrical storm.

• Check Your Pet's Safe Areas

After a storm has ended, check all of your pet's safe areas before you put the Computer Collar back on him. Use the following procedure to make sure that your system is continuing to work properly.

Hold the Computer Collar collar so that the receiver is at about the same height and on the same angle that it is when your pet is wearing it, and move throughout his safe areas. This should include all of the safe areas where your pet is allowed to go, in your yard and in your home.

If the receiver sounds a warning when it is in a safe area, DO NOT put the Computer Collar back on your pet. Immediately call your local Invisible Fence professional for service.

Use a leash or other means to contain your pet until after the service has been completed.

• At Least Once a Month, and After a Thunder Storm, Check the Width of Your Invisible Fence System's Signal Field

Always keep a note of the width of your system's signal field.

You only have to check the width of the signal field from one place on the signal field loop wire. Always check the signal field from the same place.

Take the Computer Collar off your pet. Follow the instructions for checking the width of the signal field on page 9.

If the receiver does not sound a warning where the edge of the signal is supposed to be, or if it only sounds a warning when it is closer to the wire than the setting of the signal field, immediately call your Invisible Fence professional for service.

Use a leash or other means to contain your pet until all necessary service has been completed.

ICT 775 Transmitter Installation

Features and Functions

The operating frequency of the ICT 775 is factory set to 7K and cannot be changed.

An ICT 775 transmitter is designed for two different applications. The first is for a system that will need a very large signal field wire. The ICT 775 is designed for a system with a signal field wire that will consist of 2,000 to 5,000 feet(610 to 1525m) of signal loop wire, with up to 200 feet(61m) of twisted pair. This transmitter will typically produce a signal field from a 2,000 foot signal field loop that is a minimum of 5 feet to a maximum of 25 feet(1.5 to 7.6m) wide.

The second application that an ICT 775 is designed for is to power a 3 sided system, using two, 8 foot(2.4m) grounding rods with an opening of up to 150 feet(45.74m), connected to up to 2,000 feet (610m) of 12 gauge signal field loop wire, and up to 200 feet(61m) of twisted pair. In the three sided mode, the ICT 775 will typically produce a signal field that can be adjusted from 5 to 15 feet(1.5 to 4.6m) wide.

There is a loop type selector switch on the top, left of the transmitter's circuit board that must be set

to Normal, the UP position, for a system with a standard closed signal field wire, or to 3 Side, the DOWN position, for 3 sided system operation.

There is one signal field wire connector on the bottom, right hand side of the circuit board, and one signal field adjustment knob to set and adjust the width of the signal field.

The ICT 775 has a green LED that indicates when the power is on, that the signal field wire is connected to the transmitter, and that there is not a break in the signal field wire. When the system is operating as it should, in either mode, the LED is alternately ON for 1 second and OFF for 4 seconds.

An ICT 775 has both visual and audible wire break indicators. If the signal field wire is broken or disconnected from the transmitter, the LED will be green and stay ON without blinking and the BreakAlert® will sound an alarm. The wire break alarm is a rapid, continuous four beeps per second.

The LED will stay on and the alarm will sound until the break is repaired, or the signal field wire is reconnected to the transmitter, or all power to the transmitter is turned off by unplugging the trans-

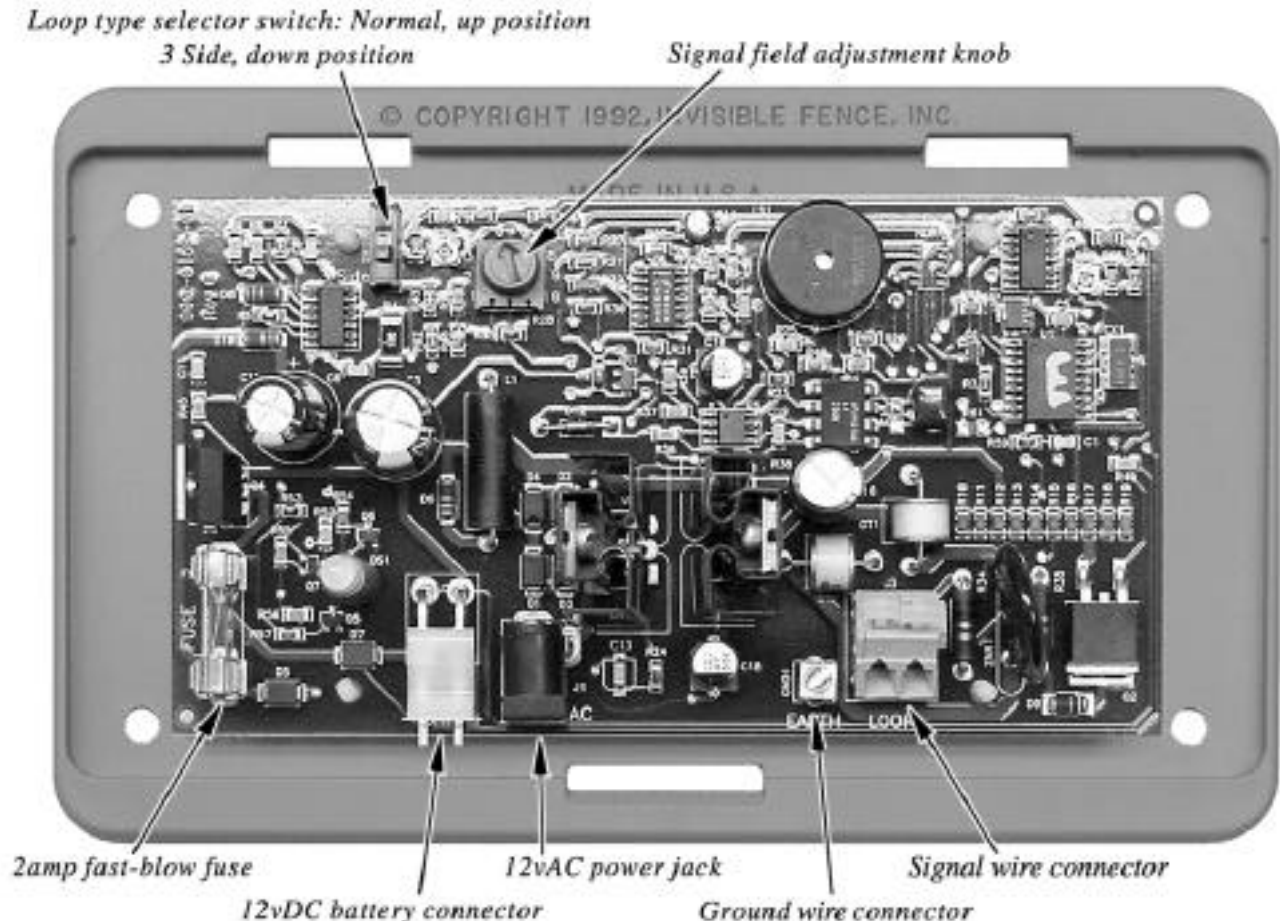

former from the 110vAC outlet and the transmitter, and if the system has a backup battery, the battery is also disconnected from the transmitter.

The ICT 775 transmitter has an internal battery backup circuit that will automatically charge an external 12vDC battery. With a charged 12v battery the ICT 775 will continue to power the signal field wire if there is a 110vAC electric power failure.

The ICT 775 has built-in, non-replaceable, loop side lightning surge protection.

Removing the ICT 775 Cover

To take the cover off the transmitter, hold the base of the transmitter in one hand and, using the thumb

and index finger of your other hand, gently compress the top and bottom of the cover plate and remove it.

To put the cover back on, align the two tabs on the top of the cover plate with the two slots, on the top of the base, and slide the tabs into the slots. Lock the cover in place by sliding the bottom tab of the cover plate into the bottom slot in the base.

The Signal Field

Invisible Fence® transmitters produce a coded, low power radio signal which travels from the transmitter, along the signal field wire and back to the transmitter to produce an Invisible Barrier® wall. This signal is what activates your pet's Computer Collar® receiver.

There is no hazard in touching or exposing the wire because the wire carries only harmless low voltage electricity.

The ICT 775 system functions only when the signal field wire forms one continuous circuit. The signal field is created where two sides of the wire are separated and is cancelled where two sides are kept close together or are twisted together. If there is a break in the signal field wire, the signal field will be lost and the system will cease to function.



ICT 775 system with a backup battery and an Invisible Sentry™ system monitoring the signal field wire.

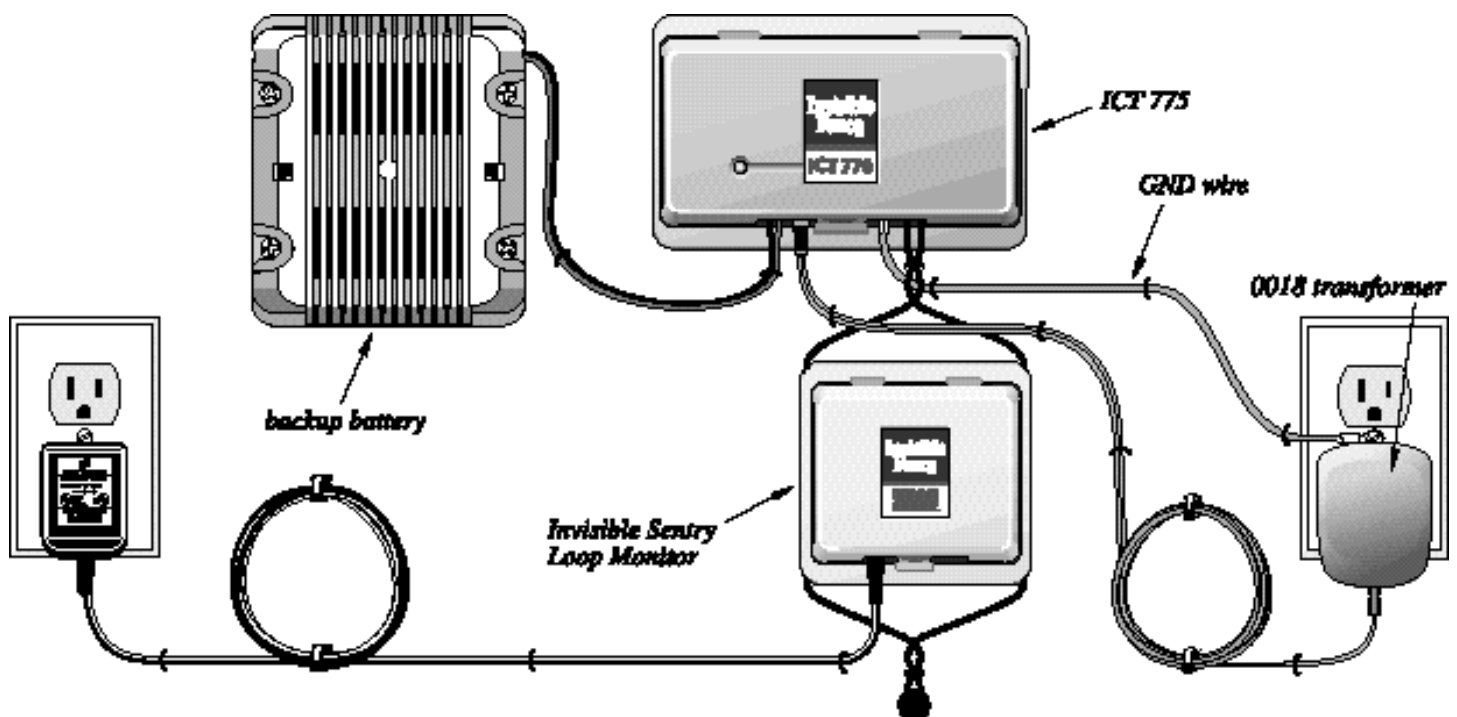

Planning the Installation

Install the transmitter in a dry indoor location, near a grounded 110vAC electric outlet that offers easy access to the outside. A garage or basement is usually the best location. If you are not sure whether your outlets are grounded or not, contact your electrician. To fasten the transmitter on a wall, use 3/4 inch(19mm), #8 or #10 pan-head sheet metal screws through the four round holes in the base of the transmitter case.



Caution: *Never install a system or any equipment, or service any equipment, during a thunder or electrical storm, or when a thunder storm is near your area.*

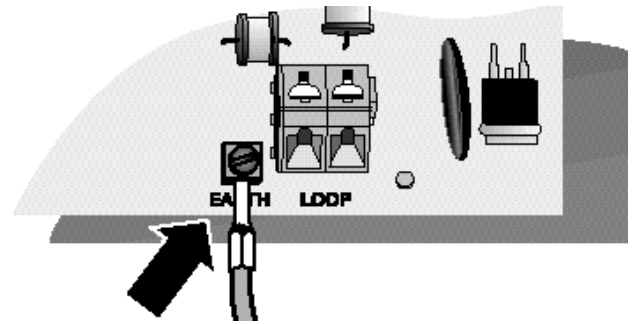

that it is snug against the ground wire pin. Then tighten the screw an additional 1/4 turn.



Note: *DO NOT tighten the screw more than a 1/4 turn when tightening the grounding wire screw clamp.*

Over tightening the screw that holds the grounding wire pin may shear off or fracture the EARTH ground connector and greatly reduce the quality of the electrical connection. A sound earth ground connection is essential and required for lightning protection and the safety of the system.



Caution: *Never use a transmitter when the EARTH ground connector on the circuit board is partially sheared or fractured.*

Grounding the System



Caution: *Before starting any work, you must unplug the 12vAC transformer and turn off the electric service at the circuit panel.*

All outdoor Invisible Fence pet containment systems are equipped with lightning surge protection, which is designed to prevent damage to the transmitter in the event of an electrical surge.

If the system is properly installed and grounded, and is equipped with an Invisible Fence lightning protection device, Invisible Fence will repair or replace, at our option, any transmitter, transmitter circuit board, transformer, or lightning protector damaged by an electrical surge for as long as the original owner owns the system.

Before you connect the signal field wire, or backup battery, or connect the transformer to the transmitter, you must ground the system.

Connecting the Grounding Wire to the ICT 775 Circuit Board

Put the grounding wire pin into the square screw clamp marked EARTH on the transmitter circuit board. Be careful not to push the pin too far through the connector. The grounding wire pin must not touch any other component on the circuit board. Use a flat head screwdriver with a 1/8 inch(3.2mm) wide blade to tighten the connector screw only enough so

Grounding Instructions to an Electric Outlet

Remove the screw that holds the cover on the grounded 110vAC electric outlet. Put this screw through the grounding wire ring terminal. Then put the screw, with the ring terminal through the outlet cover plate and screw it back into the outlet. The grounding wire must be on the outside of the outlet cover. If the cover plate screw is plastic, replace it with a size 6-32 x 1/2 inch oval-head metal screw.

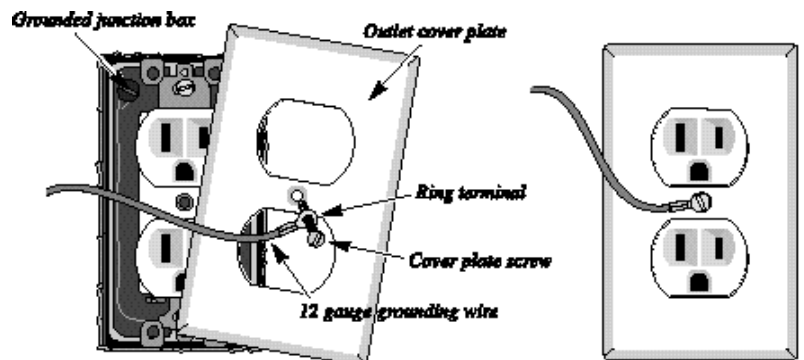

IMPORTANT: During the grounding process, make sure that the screw and the threads in the outlet are clean. All foreign matter such as paint, corrosion, grease, and dirt must be removed. There must be metal to metal contact of the mating threads. Also, the underside of the screw head and ring terminal must be clean. If the surfaces appear corroded, scrape, wire brush, or sand each thoroughly, or replace them.



Caution: *DO NOT* make any sharp bends in the grounding wire.

Grounding Instructions to a Ground Fault Circuit Interrupter, GFCI Receptacle

Definition: A GFCI receptacle provides a function similar to a circuit breaker. When it detects a ground fault in the circuit's electric current the GFCI trips and cuts the power. A ground fault is an abnormal electrical condition which is not desirable.

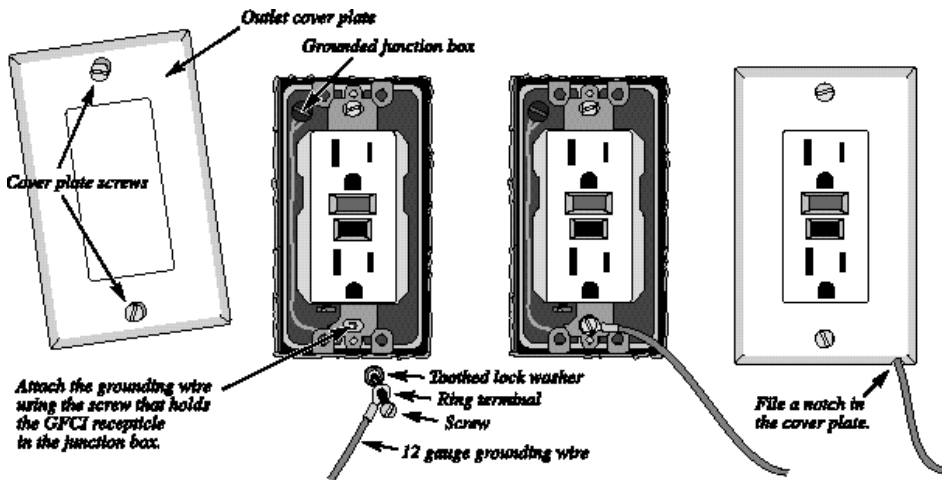

1. Remove the outlet cover plate.
2. Remove the bottom screw holding the GFCI outlet in the junction box.
3. Put the screw through the grounding wire ring terminal.
4. Refasten the screw, with the ring terminal on it, to the GFCI junction box and tighten it.
5. File a notch in the bottom edge of the cover plate slightly larger than the diameter of the 12 gauge grounding wire. Bend the wire to fit in the notch and reattach the cover plate keeping the wire in the notch.

the Invisible Fence® system operating if there is an electric utility power outage. A fully charged 12vDC battery with a 5.0Ah(Amp hours) rating will power the system for approximately 10 hours with the signal field set to the maximum width. Conversely, the narrower the signal field is set, the longer the battery will continue to power the system.



Warning: *Never connect a backup battery to a transmitter while 110vAC power is being supplied to the transmitter. Before you connect the battery make sure that the transformer is unplugged from both the 110v outlet and the transmitter.*

A backup battery should always be installed in an Invisible Fence battery box. The box is made of corrosion proof, impact resistant ABS plastic to securely hold the battery in place. It has integral, internal reinforcing ribs that add structural strength and keep the battery level, and is ventilated to prevent heat buildup.



Warning: *If an external backup battery is left unprotected or on the floor or the ground, this may lead to premature battery failure.*

Install the battery box on the wall near the transmitter. Hold the battery box on the wall where you want to fasten it and use the round holes through the back edges of the box as a template to mark the wall where you will drill the holes for the fasteners.

Lace a 16 inch(40.6cm) long zip tie through the two holes in each side of the inside front corners of the battery box. The zip tie should form a U inside the middle of the box.

The outboard ends of the two battery wires, the ends that are connected to the terminals on the battery, each have a spade quick-connect.

Connect the spade quick-connect on the RED wire to the positive (+) terminal on the 12v battery.

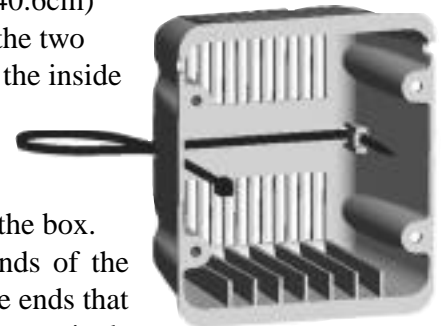

Installing a Battery Backup

An external 12vDC battery connected to an ICT 775 transmitter will supply the power needed to keep

Connect the spade quick-connect on the BLACK wire to the negative (-) terminal on the 12v battery.

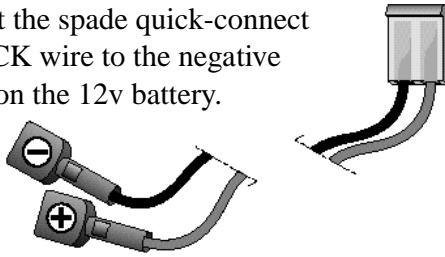

Caution: Be careful not to reverse the RED and BLACK wires when you connect them to the terminals on the battery. The RED wire is positive(+) and the BLACK wire is negative(-).

Slide the battery into the battery box. The bottom of the battery should sit on the internal reinforcing ribs on the bottom of the box.



When the battery is in the battery box, cinch the zip tie tightly around the battery to hold the battery securely in the box.



Use 4, 3/4 inch(19mm), #10 pan-head sheet metal screws to fasten the battery box to the wall.

After the battery box has been fastened to the wall, connect the battery to the transmitter's circuit board.

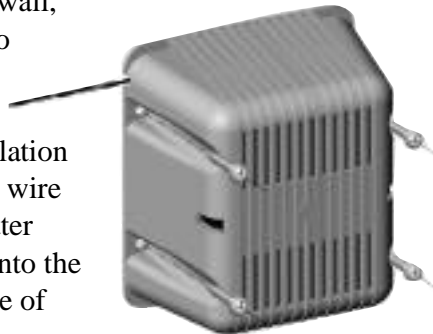

Finish the installation by feeding any loose wire between the transmitter and the battery box into the hole on the back edge of the battery box.

ICT 775 transmitters have a two position header-connector that the plug holding the two leads from the battery is plugged into. The rectangular connector has two metal prongs and is labeled - BATT +. It is located on the bottom, left of the transmitter's circuit

board between the LED and the 12vAC Power Jack.

The battery connector is designed so that the plug that holds the two inboard ends of the wires that are connected to the battery will only go into it one way, making it nearly impossible to reverse the battery wire connections at the transmitter.

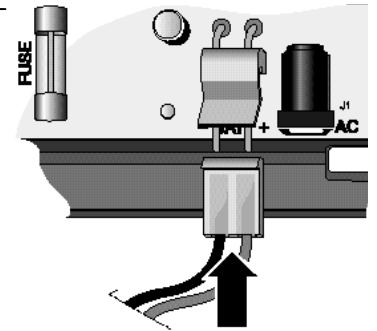

There is a replaceable, 2amp fast-blow fuse on the bottom left side of the transmitter's circuit board to protect the transmitter and the battery. If the wires are accidentally crossed when they are connected to the battery, or if the plug is connected to the transmitter incorrectly, the fuse will blow.

Batteries Recommended by Invisible Technologies, Inc., are all 12vDC, 5.0Amp hours.

Approved Batteries

All are lead-acid, 12vDC, 5.0Ah.
 Power Mate®, PM1255;
 Power Sonic®, PS-1252;
 Panasonic®, LCR12V5P;
 Cell-Con, PN 90195



Warning: Only use one of the approved lead-acid batteries.

Using a battery that is not lead-acid, or a battery with a different voltage can damage both the transmitter and the battery.



Note: The recommended 12vDC lead-acid batteries have a five year shelf life, and should be replaced,

whether they have been engaged often or not, after that time.

Detecting Low Voltage in the Backup Battery

After a 12v battery is fully charged, a micro-processor in the transmitter will automatically check the battery's voltage. If the voltage of the battery

drops between 11vDC and 9vDC, the transmitter's BreakAlert® alarm will sound. The low battery alarm will continue until 110vAC power is restored and the battery voltage is recharged to greater than 11vDC. The alarm is a single, one second beep that will sound once a minute.

The LED on the transmitter that is green during normal operation, will turn red indicating that there is a 110vAC power failure and that the system is operating on 12vDC battery backup power. The red LED will alternately blink ON for one second and OFF for four seconds.

A fully discharged 5.0Ah battery will take five times its projected operating time to completely recharge. The battery will take about 50 hours to fully charge. The transmitter automatically charges the backup battery while the system is operating normally on 110vAC power.



Note: How long it will take the battery to recharge to 11vDC will depend on how low the battery's voltage has dropped and how wide the signal field is. The lower the voltage is and the wider the signal field is, the longer it will take to recharge the battery.



Note: A battery will take five times its rated operating time to fully charge.

A 5.0Ah battery will take about 50 hours to charge to full power.

If the voltage of the battery drops too low to produce a signal field, the LED will not be lit.

Connecting the Signal Field Wire

Connect the twisted pair ends of the signal field wire to the ICT 775. Strip about 1/4 inch(6.4mm) of insulation off each of the two ends of the twisted wire. Twist the exposed wire strands on each end of the wires together to hold the strands together. You want to make sure that a loose strand on one end of the wire does not touch the other end of the wire, or the other opening in the wire connector, or any other component on the transmitter's circuit board.

Connect each end of the twisted pair to the ICT 775 signal field wire connector labeled LOOP.

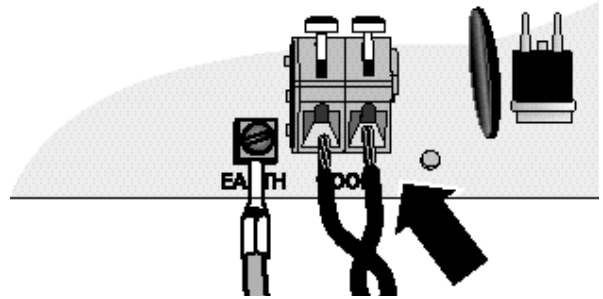

Use your thumb to push back and down hard on the white tabs located on top of the signal field wire connector. While holding down the tabs, put one stripped end of the twisted wire into each of the openings in the connector. Either end of the wire may be put into either opening. Hold the ends of the wire in the openings and release the tabs. The ends of the wire will automatically be crimped into the wire connector.

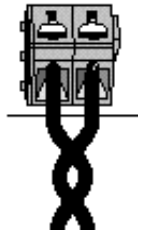

Note: You will have to apply pressure to push down the white tabs on the connector; the connector will not break, so do not be concerned about pushing too hard.

To remove the signal field wire from the connector, push back and down on the tabs on the connector and pull the ends of the wire out.



Note: Before you turn on the power to the ICT 775 system be sure that the loop type selector switch is in the mode that you will want it to be. Either the Normal position, UP, for a closed signal field wire, or the 3 Side position, DOWN for a three sided system.

Loop type selector switch in the Normal, up position.

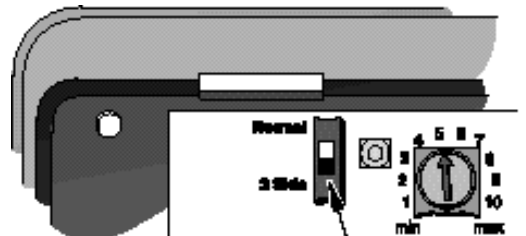
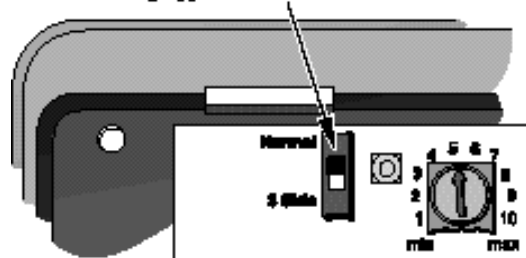

Loop type selector switch in the 3 Sided, down position.

ICT 775, 12vAC Transformer, Model 100-0018-01

Only use the model 100-0018-01, 12vAC transformer to supply the power to an ICT 775 system. This transformer will supply the power necessary to power the ICT 775. Specifications:

INPUT: 120vAC 60Hz 33.5W
OUTPUT: 12vAC 1667mA
UL/CSA CLASS 2 Transformer
UL listed/CSA certified



Warning: *The model 100-0018-01 is the only transformer authorized by Invisible Technologies, Inc. to be used to supply the power to an ICT 775. The use of any other transformer may result in a malfunction of the transmitter and the ICT 775 system.*

When you turn on the power to an ICT 775 transmitter, it will take the transmitter up to 1 minute to stabilize. While the transmitter is stabilizing the BreakAlert® alarm will sound. After the transmitter has stabilized and the alarm has shut off, proceed to set the width of the signal field

If the alarm continues to sound for more than a minute, there is a problem with the signal field wire.



Caution: *Always be sure to take the Computer Collar® off your pet before setting the signal field or making any adjustment to your Invisible Fence® System.*

Setting and Checking the Width of the ICT 775 Signal Field

A signal field that is broadcasted out from the signal field wire is what activates your pet's Computer Collar receiver. The signal field can be set to various distances from a signal field wire loop depending on the layout and size of your property, and the temperament of your dog. The average setting of the signal field is 6 to 10 feet (1.8 to 3m) wide.

Check to be sure that the transmitter is turned on and that the loop type selector switch is set to the type of system that you have. For a standard closed system with a continuous signal field wire, the switch is set to Normal, the UP position. For a 3 sided system, the switch is set to 3 Side, the DOWN position.

The width of the signal field is set and checked in exactly the same manner, whether for a standard system with a closed signal field loop, or for a 3 sided system.

The signal field adjustment knob is near the top of the ICT 775 circuit board, it is surrounded by the numbers 1 to 10. Turning the signal field adjustment knob clockwise increases the width of the signal field and counter clockwise decreases the width.

These adjustments do not change the correction level of the receiver, they only change the width of the signal field from the signal field wire loop.

Start by turning the signal field adjustment knob to 5, the mid range.

Once again, wait up to 1 minute for the transmitter to stabilize before you check the width of the signal field with a Computer Collar receiver. The BreakAlert® may initially sound an alarm until the transmitter stabilizes.

After the transmitter has stabilized, check the width of the signal field by holding a Computer Collar so that the receiver is parallel to the loop wire. Hold the collar so that the receiver is at about the same height and on the same angle that it will be when your pet is wearing it and walk slowly toward the signal field loop wire. The receiver will sound a warning when it is at the edge of the signal field.

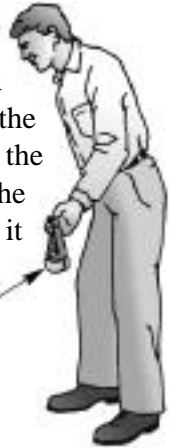

Note: *A Computer Collar® receiver has a fail safe mechanism.*

The receiver will go through three complete cycles of 10 seconds on and 10 seconds off and then shut down. It will not reactivate until it is taken completely out of the signal field, and is then brought back into it.

Make small gradual adjustments with the signal field adjustment knob and check the width of the signal field after each adjustment.

After checking the width of the signal field, wait 1 minute before you change the setting of the signal field again, and 1 more minute before checking the width of the new signal field setting.

Computer Collar® Receivers

CAUTION AND CARE

An Invisible Fence® Computer Collar will not work unless:

1. You train your pet as prescribed in the “*Invisible Fence SafeDog® Training Manual*”.
2. The Computer Collar is worn snugly on your pet’s neck under the lower jaw.
3. The Computer Collar is adjusted so that the receiver’s posts are touching your pet’s skin.
4. The Power Cap® battery in the Computer Collar receiver is good and is correctly installed, see “*Changing the Computer Collar Receiver’s Power Cap Battery*” on page 11.
5. The transmitter is on, connected to the signal field wire, and producing a signal field along the entire signal field wire.
6. The signal field wire is intact and making a complete circuit.

The following precautions should also be taken:

1. Always take the Computer Collar off your pet before you make any adjustment to your Invisible Fence system.
2. Gradually allow your pet to become accustomed to its new Computer Collar. Take off the collar every night during the first month and periodically thereafter. This will ensure proper fit and avoid the possibility of any irritation that the posts may cause to your pet’s skin.
3. Check the Computer Collar near your television set(s). Although the receiver has a decoding circuit, some televisions may produce a coded signal similar to the Invisible Fence signal and may cause the receiver to activate when it is close to a television.

4. **DO NOT** secure the correction posts in the receiver with any kind of glue or adhesive. **ALWAYS** use the post tightening tool to tighten the receiver posts.



5. Check the transmitter periodically to make sure that it is operating properly and producing a signal field.

6. **NEVER**, under any circumstances, use this product for any purpose other than that stated in this manual. Invisible Fence systems are designed for animal use only.

Features and Functions

Computer Collar receivers are water resistant, microprocessor controlled units powered by a special 3v lithium Power Cap battery.

An R series Computer Collar can be used with all ICT700 series, Invisible Gate®, and IFA 12 transmitters.

Computer Collar receivers are available with Short, Long, or Short-Space receiver posts to fit different size dogs and work well with any type of coat

Computer Collar receivers can be fitted with shunts to reduce the correction level of the receiver for small pets who are shy or timid.



R21 v3 Series Receivers

The R21 v3 Computer Collar receivers have an added feature. The v3 will beep once when a Power Cap® battery is installed. The beep indicates that the microprocessor in the receiver is working and that the Power Cap battery has enough voltage to



power the receiver.

The three small circular indentations, equidistantly spaced around the outer edge of the base that supports the center battery contact in the receiver, indicate that the receiver is an R21 v3 series Computer Collar.

Fitting the Computer Collar

To work properly, the correction posts on the Computer Collar receiver must touch your pet's skin. Posts are available in three different sizes to ensure a proper fit for every pet: short, 1/2 inch; long, 3/4 inch; and short-spaced posts. Adjust the collar so it's snug enough to slide one finger between a post and your pet's neck. The receiver should be positioned underneath your pet's neck with the posts pointing up and the top of the receiver pointing forward, toward your pet's nose. Periodic adjustment of the Computer Collar may be necessary as your pet's coat, weight and age

Make sure that the Computer Collar is snug enough for the posts to touch your pet's skin. Be sure that you can still work a fingertip between the skin and the post.

Computer Collar
Slip or Woodhouse Collar, is only used during training



change.

Changing the Computer Collar Receiver's Power Cap Battery

The Power Cap battery is a replaceable 3v lithium battery with a unique plastic screw cap. It is very important for proper operation that the receiver always has a good Power Cap battery installed. On average, the battery should be changed every 3 to 4 months. But battery life can be reduced by several variables, including lower temperatures, the number



of times a pet challenges the system boundary, and the fit of the collar on the pet's neck. In cold weather, for example, it may be necessary to replace the battery more often. Your Invisible Fence professional should recommend a schedule for regularly changing a receiver's battery. We recommend that you ask your Dealer about a battery replacement plan.



Note: Invisible Technologies, Inc. recommends that a customer subscribe to a battery replacement plan where fresh Power Cap batteries are mailed directly to them on a regular schedule. Your Invisible Fence professional can determine the best schedule for you.



Warning: The use of any battery other than a battery authorized by Invisible Technologies, Inc. can cause a receiver to operate erratically. Failure of the receiver due to the use of an unauthorized battery, may result in denial of a warranty claim.

Invisible Fence® receivers are water resistant, they are not waterproof. In particularly humid climates or when a dog has access to creeks, pools, etc., water may get trapped in the battery compartment. A small rubber O-ring around the battery cap will minimize water invasion, but if you think that the battery compartment is getting wet, take the battery out of the Computer Collar receiver when your dog is not wearing the collar. This will allow the battery and the compartment to dry.

To remove an old Power Cap® battery from a Computer Collar receiver, use a small, thin coin in the slot on top of the battery and turn it counter clockwise. The battery will rotate up and out of the battery chamber. Never use a screwdriver to remove or tighten the battery because you may strip the plastic head on top of the battery.



Note: Remember, before you put in a new Power Cap battery, you must wait

for a full five minutes so that the Computer Collar receiver's microprocessor has enough time to recycle after the old battery has been removed.

To install a new battery, line up the two lugs on the bottom of the Power Cap with the two grooves in the sides of the battery chamber. Gently put the Power Cap into the chamber while turning it clockwise with your fingers. Finally, use a small, thin coin in the slot on the top of the battery to turn the battery clockwise until the slot on the

top of the battery is lined up with the two small raised tabs on the bottom of the receiver.



When the new Power Cap is in, wait 10 seconds before taking the receiver into the signal field to give the receiver time to recycle.

Failure to follow these directions exactly, may result in the Computer Collar receiver not activating properly. To maintain optimum performance, we recommend that you periodically test the battery.



Warning: *The Power Cap battery case is made of soft, protective material.*

The use of unnecessary force may damage the case and render the battery inoperable.



Warning: *NEVER open a Power Cap, dispose of it in fire, recharge it, heat it above 212°F(100°C), or expose its contents to water. Doing so can cause leakage or explosion and may lead to personal injury.*

Power Cap Battery Tester

We strongly recommend that each customer obtain a Power Cap battery tester. At least once a month, check the receiver battery with the Power Cap battery tester to be sure that your pet will stay out of areas that it is supposed to, and remain safely within your Invisible Fence system.

The Power Cap battery tester measures the internal resistance of a Power Cap battery and shows how much life is left in the battery.

To test a receiver battery with the Power Cap battery tester, remove the battery from the receiver and

put it into the Power Cap battery tester the same way that you would put it into a receiver. If the battery is good, the green and red LEDs on the tester will both light. If neither LED on the tester lights, or just the red LED lights dimly, the battery needs to be replaced.



Signal Field Wire Specifications

Signal field wire is solid or stranded copper, insulated wire, which carries a harmless radio signal. There is no hazard in touching or exposing the wire because the wire carries only low voltage electricity.

Some installations are unique. The following measurements are guidelines for typical Invisible Barrier® signal field wire installations.

ICT 775 STANDARD CLOSED SYSTEM			
Feet of Loop Wire	2000-3000	3100-4500	4600-5000
Feet of Twisted Pair	Up to 200		
Wire Size	12 AWG	10 AWG	8 AWG
Insulation	PE .045"		PE 60mil Jkt

ICT 775 3 SIDED SYSTEM	
Feet of Loop Wire	Up to 2000
Feet of Twisted Pair	Up to 200
Wire Size	12 AWG
Insulation	PE .045"
Grounding Rods	8' deep, with a maximum separation of 150'

Service Diagnostic Questions

SYMPTOM	CAUSE
Pet Getting Out	<ul style="list-style-type: none"> • Dead or weak Power Cap® receiver battery • Computer Collar® not adjusted properly • Break in signal field wire • Power not supplied to transmitter or power is out • Pet needs additional training • Signal field is too narrow
Beeping Sound & LED Steady (Green or Red)	<ul style="list-style-type: none"> • Break in signal field wire • Signal field wire not connected to transmitter • Power surge to transmitter
LED Not Lighted (Green or Red)	<ul style="list-style-type: none"> • No power from 110v outlet or battery back up • Transformer plug is loose or disconnected • Power surge to transmitter
Computer Collar Receiver Not Working	<ul style="list-style-type: none"> • Dead Power Cap® receiver battery • Signal field wire is disconnected • Signal field is too narrow

If, for any reason, your Invisible Fence® system does not operate as described in this manual, or if you encounter any difficulty training your pet, please call your Invisible Fence professional immediately.

Important Warnings



1. WARNING: *Occasionally an animal cannot be trained to avoid crossing the Invisible Boundary®. Sometimes even a properly trained animal may cross the boundary. Therefore, Invisible Technologies, Inc, Invisible Fence Distributors and Dealers cannot guarantee that the system will, in all cases, keep Customer's animal within the established boundary. Accordingly, if Customer has reason to believe that his or her animal may pose a danger to others or harm itself if it is not kept from crossing the boundaries, Customer should not rely solely upon the system to keep the animal from crossing the boundary.*



2. WARNING: *The control panel component of the system includes visual and audio signals to warn of a system malfunction, and is therefore intended to be installed in a place where such signals may be easily seen and heard. If the control panel is installed in an enclosed box or in a place not readily accessible to Customer, Customer will forfeit the benefits of the system's warning functions for which Invisible Technologies, Inc., Invisible Fence Distributors and Dealers assume no responsibility.*



3. WARNING: *Some persons claim that the shock from an electronic receiver collar can provoke an animal to become aggressive, and possibly to attack or bite. Customer is hereby warned to be alert for growling, snarling, biting, or other aggressive behavior by any animal using the system, especially during training. If any such behavior is observed, particularly if it appears to be associated in any way with the system, Customer should immediately stop using the system, unplug the transmitter, and contact your local Invisible Fence professional or Invisible Technologies, Inc. Reported incidents have typically involved:*

- 1) dogs with pre-existing aggressive tendencies; and*
 - 2) other provocation at the time of the incident.*
- Reports to Invisible Technologies alleging such incidents are rare, less than one in 10,000, or 0.01% of the time.*



© 2003 Invisible Technologies, Inc., 1000 Fuller Drive, Garrett IN 46738. Made in USA. Printed in USA. Invisible, Invisible Fence, Invisible Fencing, Invisible Barrier, Invisible Boundary, Invisible Power, Cloture Invisible, Inbounds, Softwear, Power Cap, Safe Dog, Invisible Mask, SuperDog, Computer Collar, Break Alert, Off Limits, Your Neighborhood Pet Containment Professionals, Sharing the Responsibility For Your Pet's Well-Being, The Fence that Make Sense, Always There . . . For The Life of Your Pet, Pet Central, Premium Dog Management, The Visible Difference, Pet Keeper, Room Keeper , In-Home, Project Pet Save, Invisible Fencing Celebrating 25 Years Protecting Pets & Design, The One and Only, Original, Pet Safety System, Invisible Fence Brand , Your Dog Safe @ Home and Invisible Gate are registered trademarks of Invisible Technologies, Inc. Pro Dog, Invisible Fencing Dogs' Life, Invisible Sentry, Safe Cat, and Your dog is so much more than a pet. are trademarks of Invisible Technologies, Inc. Invisible Fence Brand products are covered by various patents, both domestic and foreign. Trademark uses licensed. Trademark owner: Invisible Technologies, Inc., USA.

Questions or comments? Please call 1-800-538-DOGS or visit www.invisiblefence.com.